

**SL. No. : G**

ಒಟ್ಟು ಪ್ರಶ್ನೆಗಳ ಸಂಖ್ಯೆ : 50 ]

Total No. of Questions : 50 ]

**CCE PF  
CCE PR**

[ ಒಟ್ಟು ಮುದ್ರಿತ ಪುಟಗಳ ಸಂಖ್ಯೆ : 12

[ Total No. of Printed Pages : 12

ಸಂಕೇತ ಸಂಖ್ಯೆ : **81-E****Code No. : 81-E**

ಇಲ್ಲಿಂದ ಕತ್ತರಿಸಿ

**ವಿಷಯ : ಗಣಿತ****Subject : MATHEMATICS**

( ಇಂಗ್ಲಿಷ್ ಭಾಷಾಂತರ / English Version )

( ಹೊಸ ಪಠ್ಯಕ್ರಮ / New Syllabus )

(ಖಾಸಗಿ ಅಭ್ಯರ್ಥಿ &amp; ಪುನರಾವರ್ತಿತ ಖಾಸಗಿ ಅಭ್ಯರ್ಥಿ / Private Fresh &amp; Private Repeater)

ದಿನಾಂಕ : 26. 03. 2018 ]

[ Date : 26. 03. 2018

ಸಮಯ : ಬೆಳಿಗ್ಗೆ 9-30 ರಿಂದ ಮಧ್ಯಾಹ್ನ-12-45 ರವರೆಗೆ ] [ Time : 9-30 A.M. to 12-45 P.M.

ಗರಿಷ್ಠ ಅಂಕಗಳು : 100 ]

[ Max. Marks : 100

**General Instructions to the Candidate :**

1. This Question Paper consists of 50 objective and subjective types of questions.
2. This question paper has been sealed by reverse jacket. You have to cut on the right side to open the paper at the time of commencement of the examination. Check whether all the pages of the question paper are intact.
3. Follow the instructions given against both the objective and subjective types of questions.
4. Figures in the right hand margin indicate maximum marks for the questions.
5. The maximum time to answer the paper is given at the top of the question paper. It includes 15 minutes for reading the question paper.

**TEAR HERE TO OPEN THE QUESTION PAPER**

ಪ್ರಶ್ನೆಪತ್ರಿಕೆಯನ್ನು ತೆರೆಯಲು ಇಲ್ಲಿ ಕತ್ತರಿಸಿ

**Tear here****PF & PR-7008**

[ Turn over

- I. *Four* alternatives are given for each of the following questions / incomplete statements. Only one of them is correct or most appropriate. Choose the correct alternative and write the complete answer along with its letter of alphabet.

 $8 \times 1 = 8$ 

1. In the given Venn diagram  $n(A)$  is

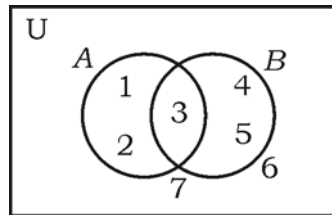

- (A) 3 (B) 1  
 (C) 5 (D) 2
2. Sum of all the first ' $n$ ' terms of even natural number is  
 (A)  $n(n+1)$  (B)  $n(n+2)$   
 (C)  $n^2$  (D)  $2n^2$
3. A boy has 3 shirts and 2 coats. How many different pairs, a shirt and a coat can he dress up with ?  
 (A) 3 (B) 18  
 (C) 6 (D) 5
4. In a random experiment, if the occurrence of one event prevents the occurrence of other event is  
 (A) a complementary event (B) a certain event  
 (C) not mutually exclusive (D) mutually exclusive event

5. The polynomial  $p(x) = x^2 - x + 1$  is divided by  $(x - 2)$  then the remainder is
- (A) 2 (B) 3  
(C) 0 (D) 1
6. The distance between the co-ordinates of a point  $(p, q)$  from the origin is
- (A)  $p^2 - q^2$  (B)  $\sqrt{p^2 - q^2}$   
(C)  $\sqrt{p^2 + q^2}$  (D)  $q^2 - p^2$
7. The equation of a line having slope 3 and  $y$ -intercept 5 is
- (A)  $3y = 5x + 3$  (B)  $5y = 3x + 5$   
(C)  $y = 3x - 5$  (D)  $y = 3x + 5$
8. The surface area of a sphere of radius 7 cm is
- (A)  $88 \text{ cm}^2$  (B)  $616 \text{ cm}^2$   
(C)  $661 \text{ cm}^2$  (D)  $308 \text{ cm}^2$

II. Answer the following :

$6 \times 1 = 6$

9. Find the HCF of 14 and 21.
10. The average runs scored by a batsman in 15 cricket matches is 60 and standard deviation of the runs is 15. Find the coefficient of variation of the runs scored by him.
11. Write the degree of the polynomial  $f(x) = x^2 - 3x^3 + 2$ .

12. What are congruent circles ?
13. If  $\sin \theta = \frac{5}{13}$  then write the value of cosec  $\theta$ .
14. Write the formula used to find the total surface area of a right circular cylinder.
- III. 15. If  $U = \{0, 1, 2, 3, 4\}$  and  $A = \{1, 4\}$ ,  $B = \{1, 3\}$  show that  
 $(A \cup B)' = A' \cap B'$ . 2
16. Find the sum of the series  $3 + 7 + 11 + \dots$  to 10 terms. 2
17. At constant pressure certain quantity of water at  $24^\circ\text{C}$  is heated. It was observed that the rise of temperature was found to be  $4^\circ\text{C}$  per minute. Calculate the time required to rise the temperature of water to  $100^\circ\text{C}$  at sea level by using formula. 2
18. Prove that  $2 + \sqrt{5}$  is an irrational number. 2
19. If  ${}^n P_4 = 20 ({}^n P_2)$  then find the value of  $n$ . 2
20. A die numbered 1 to 6 on its faces is rolled once. Find the probability of getting either an even number or multiple of '3' on its top face. 2
21. What are like surds and unlike surds ? 2
22. Rationalise the denominator and simplify : 2
- $$\frac{\sqrt{5} + \sqrt{3}}{\sqrt{5} - \sqrt{3}}$$

23. Find the quotient and the remainder when  $f(x) = 2x^3 - 3x^2 + 5x - 7$  is divided by  $g(x) = (x - 3)$  using synthetic division. 2

OR

Find the zeros of the polynomial  $p(x) = x^2 - 15x + 50$ .

24. Solve the equation  $x^2 - 12x + 27 = 0$  by using formula. 2
25. Draw a chord of length 6 cm in a circle of radius 5 cm. Measure and write the distance of the chord from the centre of the circle. 2
26. In  $\triangle ABC$   $\angle ABC = 90^\circ$ ,  $BD \perp AC$ . If  $BD = 8$  cm,  $AD = 4$  cm, find  $CD$  and  $AB$ . 2

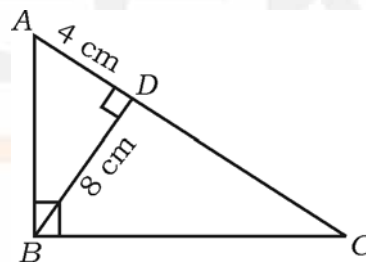

OR

In  $\triangle ABC$ ,  $XY \parallel BC$  and  $XY = \frac{1}{2} BC$ . If the area of  $\triangle AXY = 10 \text{ cm}^2$ , find the area of trapezium  $XYCB$ .

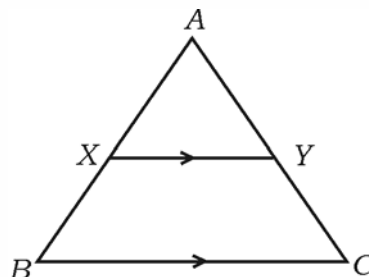

27. Show that,  $\cot \theta \cdot \cos \theta + \sin \theta = \operatorname{cosec} \theta$ . 2

28. A student while conducting an experiment on Ohm's law, plotted the graph according to the given data. Find the slope of the line obtained. 2

<i>X-axis I</i>	1	2	3	4
<i>Y-axis V</i>	2	4	6	8

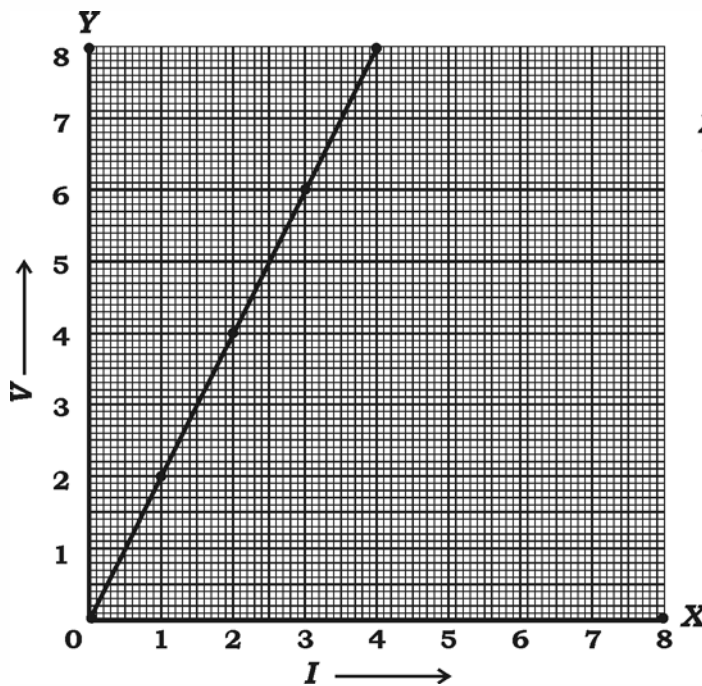

**Scale :**  
**X-axis : 1 unit = 1 cm**  
**Y-axis : 1 unit = 1 cm**

29. Draw the plan for the information given below : 2

( Scale 20 m = 1 cm )

	Metre To C	
	140	
To D 50	100	40 to B
	60	
To E 30	40	
	From A	

30. Out of 8 different bicycle companies, a student likes to choose bicycle from three companies. Find out in how many ways he can choose the companies to buy bicycle. 2
31. If  $A$  and  $B$  are two non-disjoint sets, draw Venn diagram to represent  $A \setminus B$ . 2
32. What is an Arithmetic progression ? Write its general form. 2
33. There are 10 points in a plane such that no three of them are collinear. Find out how many triangles can be formed by joining these points. 2
34. A student reads the books according to the given data. Draw a pie chart to represent it.

<i>Name of the books</i>	<i>Novels</i>	<i>Short stories</i>	<i>Magazines</i>	<i>Journals</i>
<i>No. of books</i>	10	60	20	30

- 2
35. Simplify :  $\sqrt{75} + \sqrt{108} - \sqrt{192}$ . 2
36. A polynomial  $p(x) = x^2 + 4x + 2$  is divided by  $g(x) = (x + 2)$ . Find the quotient by using division algorithm. 2
37. If  $v^2 = u^2 + 2as$ , solve for  $v$  and find the value of  $v$ , if  $u = 0$ ,  $a = 2$  and  $s = 100$ . 2

38. A vertical building casts a shadow of length 12 m. If the distance between the top of the building to the tip of the shadow at a particular time of the day is 13 m. Find the height of the building. 2
39. Show that  $(\sin \theta + \cos \theta)^2 = 1 + 2 \sin \theta \cos \theta$ . 2
40. Find the co-ordinates of the mid-point of the line segment joining the points ( 14, 12 ) and ( 8, 6 ). 2
- IV. 41. In a Geometric progression the sum of first three terms is 14 and the sum of next three terms of it is 112. Find the Geometric progression. 3

OR

- If 'a' is the Arithmetic mean of b and c, 'b' is the Geometric mean of c and a, then prove that 'c' is the Harmonic mean of a and b.
42. Marks scored by 30 students of 10th standard in a unit test of mathematics is given below. Find the variance of the scores : 3

Marks ( $x$ )	4	8	10	12	16
No. of students ( $f$ )	13	6	4	3	4

<b>PF &amp; PR-7008</b>
-------------------------



43. If  $p$  and  $q$  are the roots of the equation  $x^2 - 3x + 2 = 0$ , find the value of  $\frac{1}{p} - \frac{1}{q}$ . 3

OR

A dealer sells an article for Rs. 16 and loses as much per cent as the cost price of the article. Find the cost price of the article.

44. Prove that, "If two circles touch each other externally, their centres and the point of contact are collinear." 3
45. If  $7 \sin^2 \theta + 3 \cos^2 \theta = 4$  and ' $\theta$ ' is acute then show that  $\cot \theta = \sqrt{3}$ . 3

OR

The angle of elevation of an aircraft from a point on horizontal ground is found to be  $30^\circ$ . The angle of elevation of same aircraft after 24 seconds which is moving horizontally to the ground is found to be  $60^\circ$ . If the height of the aircraft from the ground is  $3600\sqrt{3}$  metre. Find the velocity of the aircraft.

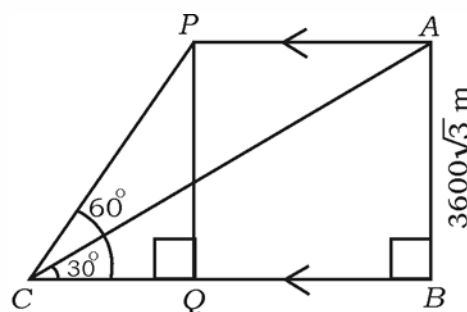

**PF & PR-7008**

[ Turn over

46. A solid is in the form of a cone mounted on a right circular cylinder, both having same radii as shown in the figure. The radius of the base and height of the cone are 7 cm and 9 cm respectively. If the total height of the solid is 30 cm, find the volume of the solid. 3

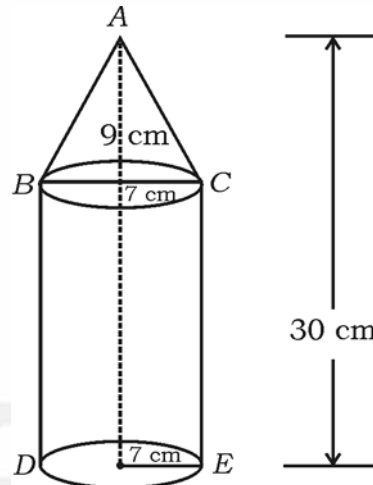

OR

The slant height of the frustum of a cone is 4 cm and the perimeters of its circular bases are 18 cm and 6 cm respectively. Find the curved surface area of the frustum.

- V. 47. Solve the equation  $x^2 - x - 2 = 0$  graphically. 4
48. Construct a direct common tangent to two circles of radii 4 cm and 2 cm whose centres are 9 cm apart. Measure and write the length of the tangent. 4
49. State and prove Basic Proportionality (Thale's) Theorem. 4

**PF & PR-7008**

50. A vertical tree is broken by the wind at a height of 6 metre from its foot and its top touches the ground at a distance of 8 metre from the foot of the tree. Calculate the distance between the top of the tree before breaking and the point at which tip of the tree touches the ground, after it breaks. 4

OR

In  $\triangle ABC$ ,  $AD$  is drawn perpendicular to  $BC$ . If  $BD : CD = 3 : 1$ , then prove that  $BC^2 = 2(AB^2 - AC^2)$ .

