

PHYSICS**SCIENCE Paper – 1***(Two hours)*

Answers to this Paper must be written on the paper provided separately.

*You will **not** be allowed to write during the first 15 minutes.*

This time is to be spent in reading the Question Paper.

The time given at the head of this Paper is the time allowed for writing the answers.

Section I is compulsory. Attempt **any four** questions from **Section II**.

The intended marks for questions or parts of questions are given in brackets [].

SECTION I (40 Marks)

Attempt **all** questions from this Section.

Question 1

- (a) Name a metal commonly used to make a calorimeter. Give a reason to support your answer. [2]
- (b) Draw a well labelled circuit diagram for the verification of Ohm's law. [2]
- (c) Why is radioactivity considered to be a nuclear phenomenon? [2]
- (d) Draw a ray diagram to show how a convex lens can be used as a magnifying glass. [2]
- (e) A metal ball of mass 60 g falls on a concrete floor from a vertical height of 2.8m and rebounds to a height of 1.3 m. Find the change in K.E. in S.I. units. [2]

Question 2

- (a) What is the work done by a force when the force is:
- (i) normal to the displacement produced. [2]
- (ii) in the same direction as the displacement produced.
- (b) State the S.I. unit of specific heat capacity and heat capacity. [2]
- (c) Draw a labelled diagram to show the path of a monochromatic light ray of light in a prism kept at its angle of minimum deviation. [2]

- (d) Explain why a single fixed pulley is used despite no gain in mechanical advantage. [2]
- (e) A metal wire has a resistance of 60Ω . It is cut into three equal lengths. Find the equivalent resistance when two parts are connected in parallel and the third part is in series with them. [2]

Question 3

- (a) Establish a relation between an electron volt and the SI unit of the physical quantity which it measures. [2]
- (b) Why is the earth pin of a three-pin plug made longer and thicker? [2]
- (c) Write the energy conversions in the following: [2]
- (i) microphone
 - (ii) lighted candle.
- (d) Mention two ways to increase the strength of an electro-magnet. [2]
- (e) What characteristics of sound would change if there is a change in its: [2]
- (i) amplitude
 - (ii) wave form.

Question 4

- (a) Which cools faster, Land or Water? Give a reason for your answer. [2]
- (b) State any two properties of α radiation. [2]
- (c) *Scissors for cutting cloth have blades much longer than handles. Why?* [2]
- (d) Two lamps, one rated $40 \text{ W}, 220 \text{ V}$ and the other having resistance 605Ω ($60 \text{ W}, 220 \text{ V}$) are connected in parallel combination across to a 220 V supply. Calculate the current drawn from the supply line. [2]
- (e) State two precautions that should be taken while handling radioactive substances. [2]

SECTION II (40 Marks)

Attempt any **four** questions from this Section.

Question 5

- (a) Show how the energy of a freely falling object remains conserved. [3]
- (b) A uniform metre rod is balanced at the 70 cm mark by suspending a weight of 50 gf at the 40 cm mark and 200 gf at the 95 cm mark. Draw a diagram of the arrangement and calculate the weight of the metre rod. [3]
- (c) Draw a diagram of a pulley system of velocity ratio 4. Calculate its mechanical advantage if its efficiency is 90%. [4]

Question 6

- (a) What is understood by lateral displacement? State two factors on which it depends. [3]
- (b) An object is kept at a distance of 15 cm from a convex lens of focal length 10 cm. Calculate the image distance and state the characteristics of the image formed. [3]
- (c) (i) Write *two* properties common to all the electromagnetic radiations.
- (ii) Give one use *each* of infrared and ultraviolet radiations. [4]

Question 7

- (a) A vibrating tuning fork is placed over the mouth of a burette filled with water. The tap of the burette is opened and the water level gradually starts falling. It is found that the sound from the tuning fork becomes very loud for a particular length of the water column.
- (i) Name the phenomenon taking place when this happens.
- (ii) Why does the sound become very loud for this length of the water column? [3]

- (b) (i) Define power of a lens. [3]
- (ii) A child is using a spectacle with power of -2.5 D. What is meant by the negative sign?
- (iii) Find the focal length of the lens used.
- (c) A man standing in front of a wall produces a sound and hears an echo after 3s. [4]
 He walks 'x' m away from the wall and produces the same sound. Now he hears an echo after 5.25s. Calculate the distance he walked away from the wall. (*Speed of sound in air is 340 m/s*)

Question 8

- (a) What is an electrical fuse? State two characteristics of an electrical fuse. [3]
- (b) What is internal resistance of a cell? Write two factors on which it depends. [3]
- (c) In the circuit diagram given below, a cell of 9V and internal resistance 0.5Ω [4]
 is connected across a resistor A of 2Ω in series and two resistors 2Ω and 6Ω which are in parallel.

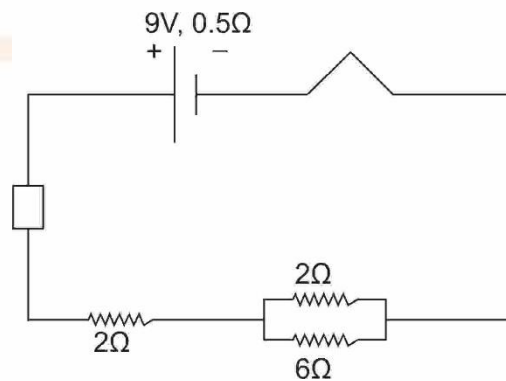

Find:

- (i) the total resistance
- (ii) the total current
- (iii) the current in the 6Ω resistor
- (iv) the potential difference across the terminals of the cell.

Question 9

- (a) (i) Define specific latent heat of fusion of ice.
- (ii) What happens to the heat supplied to the substance when the heat supplied causes no change in the temperature of the substance? [3]
- (b) Two liquids A and B have specific heat capacities $2.5 \text{ Jg}^{-1} \text{ }^{\circ}\text{C}^{-1}$ and $3.2 \text{ Jg}^{-1} \text{ }^{\circ}\text{C}^{-1}$ respectively. [3]
- (i) Which liquid is a good conductor of heat? Why?
- (ii) Which liquid is more suitable as a liquid in radiators for cooling?
- (c) A calorimeter of mass 60 g contains 180 g of water at 29°C . Find the final temperature of the mixture, when 37.2 g of ice at -10°C is added to it (specific heat capacity of water = 4200 J/kg K , latent heat of ice = $336 \times 10^3 \text{ J/kg}$, specific heat capacity of ice = 2100 J/kg K , specific heat capacity of the calorimeter is $0.42 \text{ Jg}^{-1} \text{ }^{\circ}\text{C}^{-1}$). [4]

Question 10

- (a) (i) What are background radiations?
- (ii) Write an equation of an α emission from U_{92}^{238}
- (iii) What will be the change in the rate of radioactivity if the temperature of the radioactive substance is raised to four times the initial temperature? [3]
- (b) What is nuclear fusion? Write an equation for it. [3]
- (c) (i) Draw a simple labelled diagram of the device you would use to transform 230 V AC to 15 V AC.
- (ii) What is the name of this device?
- (iii) On what principle does the device work? [4]