

**General Instructions:**

1. All questions are compulsory.
2. The question paper comprises of **two Sections, A and B**. You are to attempt both the sections.
3. All questions of **Section-A** and **Section-B** are to be attempted separately.
4. There is an internal choice in three questions of three marks each, two question of five marks and one question of Practical Based Question.
5. Question number **1 to 2** in **Section-A** are **one mark** question. These are to be answered in **one word** or in **one sentence**.
6. Question numbers **3 to 5** in **Section-A** are **two marks** questions. These are to be answered in about **30 words** each.
7. Question numbers **6 to 15** in **Section-A** are **three marks** questions. These are to be answered in about **50 words** each.
8. Question numbers **16 to 21** in **Section-A** are **five marks** questions. These are to be answered in about **70 words** each.
9. Question numbers **22 to 27** in **Section-B** are questions based on practical skills and are **two marks** questions.

### SECTION – A

1. List two functions of ovary of human female reproductive system.
2. How do the guard cells regulate opening and closing of stomatal pores?
3. What is windmill? State the energy conversion taking place in the working of a windmill.
4. Distinguish between a real and a virtual image of an object. What type of image is formed (i) by a plane mirror, (ii) on a cinema screen?
5. How can the valency of an element be determined if its electronic configuration is known? What will be the valency of an element of atomic number 9 (nine)?
6. Why does a current carrying conductor experiences a force when it is placed in a magnetic field? State Fleming's left hand rule.

**OR**

Why is pure iron not used for making permanent magnets? Name one material used for making permanent magnets. Describe how permanent magnets are made electrically. State two examples of electrical instruments made by using permanent magnets.

7. Find the current flowing through the following electric circuit.

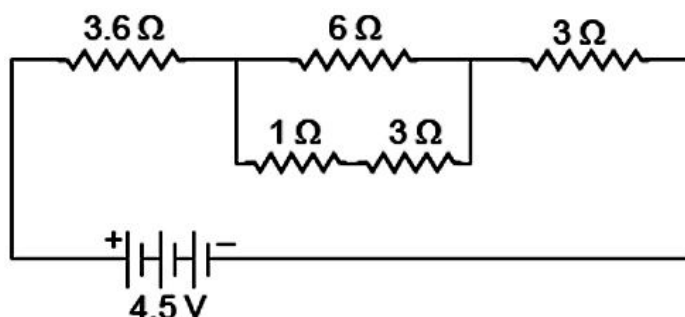

8. (a) Draw a diagram to show the nutrition in Amoeba and label the parts used for this purpose. Mention any other purpose served by this part other than nutrition.  
(b) Name the glands associated with digestion of starch in human digestive tract and mention their role.

OR

Draw a diagram of the front view of human heart and label any six parts including at least two, that are concerned with arterial blood supply to the heart muscles.

9. The element Be, Mg, Ca are placed in the second group of the periodic table. Their atomic numbers are 4, 12, 20 respectively.  
(a) Write the electronic configuration of these elements.  
(b) Write the valency exhibited by them.  
(c) Which of the three elements will be most reactive?
10. A reddish brown coloured metal, used in electrical wires, when powdered and heated strongly in an open china dish, its colour turns black. When hydrogen gas is passed over this black substance, it regains its original colour. Based on the above information answer the following questions.  
(a) Name the metal and the black coloured substance formed.  
(b) Write balanced chemical equations for both the reactions.
11. A white powder is added while baking breads and cakes to make them soft and fluffy. Write the name of the powder? Name its main ingredients. Explain the function of each ingredient. Write the chemical reaction taking place when the powder is heated during baking.

OR

State reason for the following statements:

- (a) During summer season, a milk man usually adds a very small amount of baking soda to fresh milk.  
(b) For a dilution of acid, acid is added into water and not water into acid.  
(c) Ammonia is a base but does not contain hydroxyl group.
12. What is AIDS? Which microbe is responsible for AIDS infection? State one mode of transmission of this disease. Explain in brief one measure for the prevention of AIDS.
13. A cross was made between pure breeding pea plants one with round and green seeds and the other with wrinkled and yellow seeds.  
(a) Write the phenotype of F1 progeny. Give reason for your answer.  
(b) Write the different types of F2 progeny obtained along with their ratio when F1 progeny was selfed.
14. (i) Planaria, insects, octopus and vertebrates all have eyes. Can we group eyes of these animals together to establish a common evolutionary origin? Justify your answer.  
(ii) "Birds have evolved from reptiles" State evidence to prove the statement.
15. To construct a ray diagram we use two rays of light which are so chosen that it is easy to determine their directions after reflection from the mirror. Choose these two rays and state the path of these rays after reflection from a concave mirror. Use these two rays to find the nature and position of the image of an object placed at a distance of 15 cm from a concave mirror of focal length 10 cm.
16. What is the principle of an electric motor? Briefly explain the construction and working of an electric motor using a labeled diagram. State the factors on which the strength of a motor depends.

17. (a) (i) Name the parts labelled A and B in the neuron drawn below.

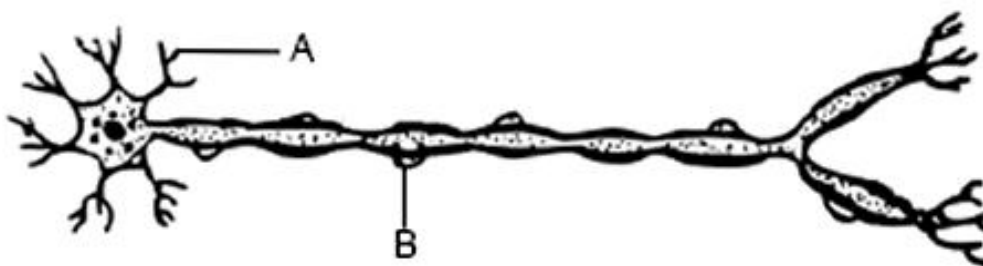

- (ii) Which part acquires the information in the neuron?
  - (iii) Through which part does the information travel?
  - (iv) In what form does this information travel?
  - (v) Where is the impulse converted into a chemical signal for onward transmission?
- (b) Name the hormone secreted by thyroid. What is its function? Why is the use of iodised salt advisable.

18. A metal (E) is stored under kerosene. When a small piece of it is left open in the air, it catches fire. When the product formed is dissolved in water, it turns red litmus to blue.

- (a) Name the metal (E).
- (b) Write the chemical equation for the reaction when it is exposed to air and when the product is dissolved in water.
- (c) Explain the process by which the metal is obtained from its molten chloride.

19. (a) Define the term 'isomers'.

- (b) Draw two possible isomers of the compound with molecular formula  $C_3H_6O$  and write their names.
- (c) Give the electron dot structures of the above two compounds.

**OR**

(a) In tabular form, differentiate between ethanol and ethanoic acid under the following heads:

- (i) Physical state
- (ii) Taste
- (iii)  $NaHCO_3$  test
- (iv) Ester test

(b) Write a chemical reaction to show the dehydration of ethanol.

20. (a) List the parts of the human eye that control the amount of light entering into it. Explain how they perform this function.

(b) Write the function of retina in human eye.

(c) Do you know that the corneal-impairment can be cured by replacing the defective cornea with the cornea of the donated eye? How and why should we organize groups to motivate the community members to donate their eyes after death?

21. (a) What is ozone? How and where is it formed in the atmosphere?

(b) "Damage to the ozone layer is a cause for concern." Justify this statement. Suggest any two steps to limit this damage.

**OR**

(a) Why is Government of India imposing a ban on the use of polythene bags?

(b) Write the harmful effects of using plastic bags on the environment.

(c) Suggest two alternatives to these bags and explain how this ban is likely to improve the environment.

## SECTION – B

22. On passing excess carbon dioxide gas through lime water, it first turns milky and then becomes colourless. Explain why? Write all the chemical equations of the reactions involved.
23. What is an oxidising agent? What happens when an oxidising agent is added to propanol? Explain with the help of a chemical equation.
24. Name the green dot like structures in some cells observed by a student when a leaf peel was viewed under a microscope. What is this green colour due to?
25. A teacher sets up a stand carrying a convex lens of focal length 15 cm at 20.5 cm mark on the optical bench. She asks the students to suggest the position of the screen on the optical bench so that a distinct image of a distant tree is obtained on it. What should be the correct position of screen as suggested by the students and why?
26. What happens when (a) Planaria gets cut into two pieces? (b) A mature Spirogyra filament attains considerable length?
27. A student has three voltmeters across three resistances  $R_1$ ,  $R_2$  and  $R_3$  as shown in the circuit. Given that  $R_1 < R_2 < R_3$  (i) Write  $V_1$ ,  $V_2$  and  $V_3$  in decreasing order of the reading shown by each of them. (ii) What will you observe about the potential difference across the series the series combination?

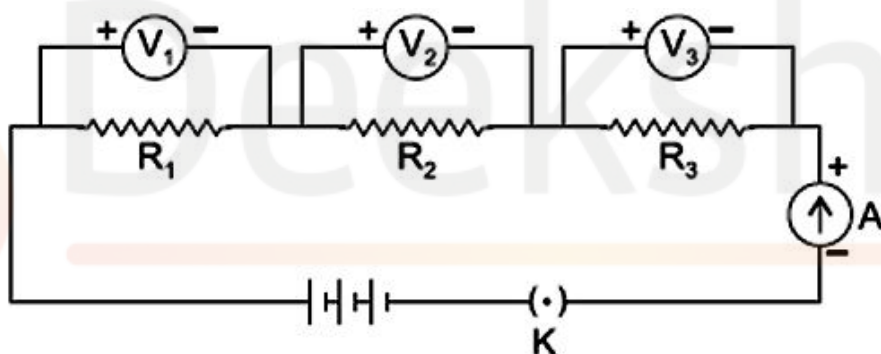

OR

- (i) Draw a schematic diagram of a circuit consisting of a cell of 1.5 V, 10  $\Omega$  and 15  $\Omega$  resistor and a plug key all connected in series.
- (ii) Which one is same in series, current or voltage ?